

Electric 3-way valve

Type CTR 20



The CTR is an electrically operated 3-way valve designed specifically for operation in CO₂ systems with heat reclaim. CTR is designed to allow full proportional control of the surplus heat from compressor pack into the heat exchanger of transcritical heat reclaim solutions.

The proportional control of the CTR ensures that the exact amount of heat required is available at any time, and the possibility to operate smoothly in changeover situations allowing for stable control.

The typical application for the CTR is a Pack/rack system in food retail application working with transcritical CO₂. Heat reclaim is the current most attractive energy advantage of transcritical CO₂. Even as transcritical CO₂ systems are on par or outperform traditional HFC installations on energy performance, this also ensures the possibility to supply high quality heat to be exploited. Heat reclaim is seeing an increased deployment and becoming a norm in most transcritical CO₂ retail installations today.

Application:

Heat reclaim in CO₂ systems (transcritical).

Features

- Full proportional and on / off control of the heat reclaim system.
- 2 inlets and 1 outlet or 1 inlet and 2 outlets.
- Applicable to R744 and other common refrigerants.
- CTR is compatible with oil types PAG and POE
- Full serviceable cartridge design valve.
- Modulating operation to ensure smooth transition.
- Leak tight, motor integrated in valve.
- Eliminates pressure peaks in heat reclaim systems.
- Controls transcritical pressure up to 140 bar.
- Available for combo weld or solder/braze.
- Standard M12 connector for easy connection to the motor driver.
- Internal / external corrosion resistant design.
- Manufactured according to ISO / TS 16943.

Архангельск (8182)63-90-72
Астана (7172)727-132
Астрахань (8512)99-46-04
Барнаул (3852)73-04-60
Белгород (4722)40-23-64
Брянск (4832)59-03-52
Владивосток (423)249-28-31
Волгоград (844)278-03-48
Вологда (8172)26-41-59
Воронеж (473)204-51-73
Екатеринбург (343)384-55-89

Иваново (4932)77-34-06
Ижевск (3412)26-03-58
Казань (843)206-01-48
Калининград (4012)72-03-81
Калуга (4842)92-23-67
Кемерово (3842)65-04-62
Киров (8332)68-02-04
Краснодар (861)203-40-90
Красноярск (391)204-63-61
Курск (4712)77-13-04
Липецк (4742)52-20-81

Магнитогорск (3519)55-03-13
Москва (495)268-04-70
Мурманск (8152)59-64-93
Набережные Челны (8552)20-53-41
Нижний Новгород (831)429-08-12
Новокузнецк (3843)20-46-81
Новосибирск (383)227-86-73
Омск (3812)21-46-40
Орел (4862)44-53-42
Оренбург (3532)37-68-04
Пенза (8412)22-31-16

Пермь (342)205-81-47
Ростов-на-Дону (863)308-18-15
Рязань (4912)46-61-64
Самара (846)206-03-16
Санкт-Петербург (812)309-46-40
Саратов (845)249-38-78
Севастополь (8692)22-31-93
Симферополь (3652)67-13-56
Смоленск (4812)29-41-54
Сочи (862)225-72-31
Ставрополь (8652)20-65-13

Сургут (3462)77-98-35
Тверь (4822)63-31-35
Томск (3822)98-41-53
Тула (4872)74-02-29
Тюмень (3452)66-21-18
Ульяновск (8422)24-23-59
Уфа (347)229-48-12
Хабаровск (4212)92-98-04
Челябинск (351)202-03-61
Череповец (8202)49-02-64
Ярославль (4852)69-52-93

Киргизия (996)312-96-26-47 Казахстан (772)734-952-31 Таджикистан (992)427-82-92-69

Data sheet | Electric 3-way valve type CTR 20

Approval (in progress)

UL, EAC, CRN, cUL



Technical data

Valve specification

Feature	CTR 20 (DN25)
Flow	1 inlet -2 outlets or 2 inlets - 1 outlet
Refrigerant	R744 (For other refrigerants please contact)
Oil Types	PAG / POE
MWP/ Refrigerant	140 bar / 2030 psig
MOPD	3 bar / 43 psi
Allowed ambient temperature range	-40 – +60 °C / -40 – +140 °F
Allowed refrigerant temperature range	0 – +150 °C / +32 – +302 °F
Environment temp (Transport/Warehouse)	-40 – +70 °C / -40 – +158 °F
Lifetime / endurance	10 years / 50.000 cycles in CO ₂ system with 3 bar diff. pressure
Serviceable	Yes

Electrical specification

Stepper motor type	Bipolar permanent motor
IP rating of electric connection	67
Step mode	Microstepping (recommended), 2 phase full step
Phase resistance	52.4 ohm ±10% per coil
Inductance	85.7 mH ±20%
Current per coil	100 mA RMS / 142 mA Peak
Holding current	20% holding current (recommended)
Duty cycle	100% duty cycle is allowed
Max. total power	Current driver: 1.2 Watt
Number of full steps	6600
Closing / opening time	88 sec @ 75 PPS
Step rate	Current control ≤ 75 step /sec. (recommended) 75 PPS for top and bottom 10% opening / closing degree and remaining at 250 pps
Electric connector type	M12
Reference position	Over drive against the full close position (both top & bottom)
Overdriving in closing direction	Recommended 3% of total step ie. 180 full steps
Recommended controller/driver	AK-XM 208C, EKD 316, EKD 316C

Material of construction (Housing)	Stainless Steel
Installation orientation	Vertical / Horizontal (Inverted not allowed)
Valve opening characteristic	Linear

Data sheet | Electric 3-way valve type CTR 20

Ordering

Valve including actuator

Type	Connection		Flow rate		Single pack	Code no
	Weld ¹⁾ [inch]	Solder ODF [inch]	k _v value [m ³ /h]	C _v value [gpm]		
CTR 20	1	1 1/8	20	23.1	1	027H7244

¹⁾ OD according to EN 10220**Spareparts**

Type	Description	Single pack	Code no.
Gasket	O-ring spare part kit for CTR 20 (3 O-rings)	1	027H7248

Related products

Type	Description	Single pack	Code no.
AK-XM 208C	Stepper output module	1	080Z0023
EKD 316C	Superheat controller / driver (preferred EKD)	1	084B8045
EKD 316	Superheat controller / driver	1	084B8040
EKA 164A	Optional display for EKD 316	1	084B8563
AST-G	Manual service driver	1	034G0013

Accessories:

M12 angle cable

M12 angle female connector is intended for use with a standard M12 male connector, available on stepper motor valves.
 This cable is designed to offer high flexibility and small outer diameters with tensile strength. The angle way M12 cable consist of paired, twisted wires, which decreases mutual influence between signals transmitted along the cable and reduces influence of external sources of interference. The cables thus provides a higher degree of protection against lost steps compared to other cables.

Approvals



Specification

Jacket	PVC - black
Cable outer sheath	Oil resistant
Water proof rating	IP 67
Operating temperature range	-40 – +80 °C / -40 - +176 °F
Wire type	Twisted pair, cross section 20 AWG / 0.5 mm ²
Cable outer diameter	7.0 mm / 0.28 inch
Minimum bending radius	10 x cable diameter
Cable combustibility / test	Flame retardant / VW-1 / CSA FT - 1
M12 standard	EN 61076-2-101
Reference standard	UL style 2464 and DIN VDE 0812
LVD directive	73/23/EEC and 93/68/EEC

Ordering

Cable	Cable length (L)	Insulation	Packing format	Code no.
PVC - black	2 m / 6.6 ft	SR-PVC	Single pack	034G7073
	8 m / 26.2 ft	SR-PVC	Single pack	034G7074

Identification

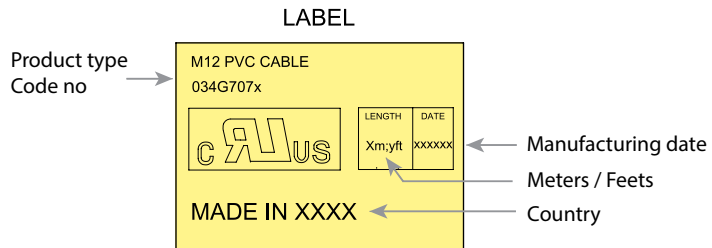

Connections



Dimensions

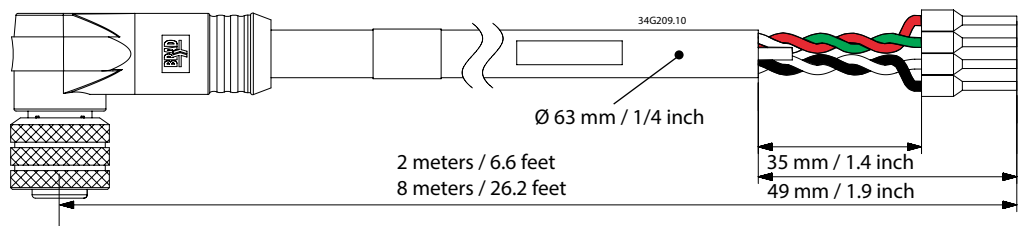

Valve design

- 1. M12 connector
- 2. Actuator
- 3. Spindle
- 4. Valve housing
- 5. Connection 1
- 6. Connection 3
- 7. Connection 2
- 8. Valve cone

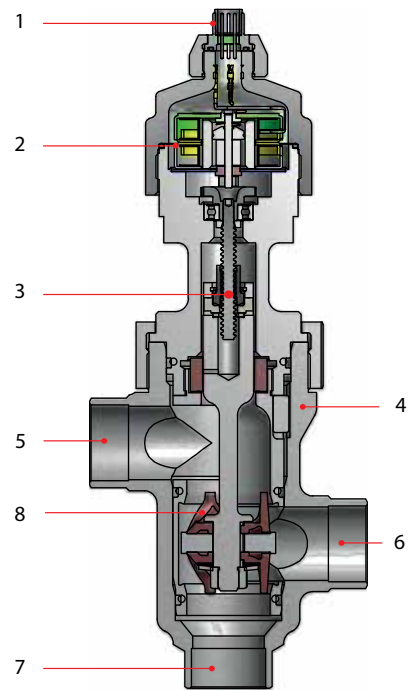

Flow direction

CTR Valve can be used in following ways as shown in the drawings.

1 inlet 2 outlets
 Connection 3 is always common inlet

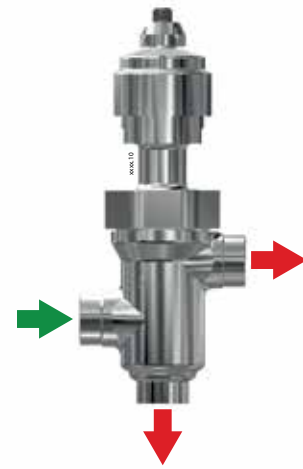
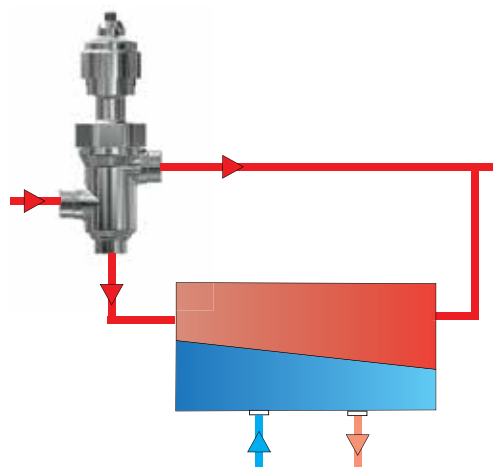

2 inlets 1 outlet
 Connection 3 is always common outlet

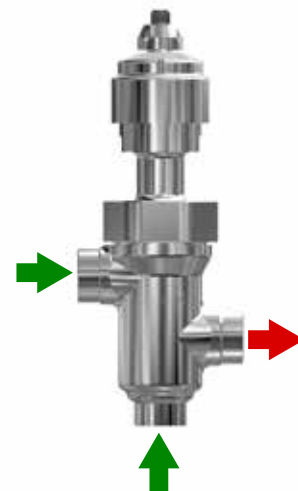
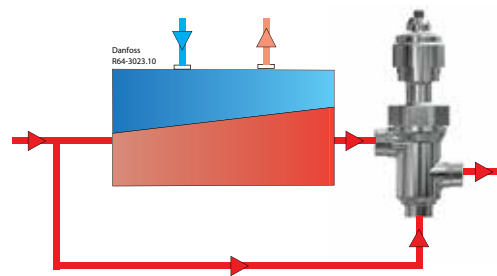

Coolselector®2

is a calculation and selection software, designed to make selection processes for all refrigeration projects easier and less time consuming.

Application example

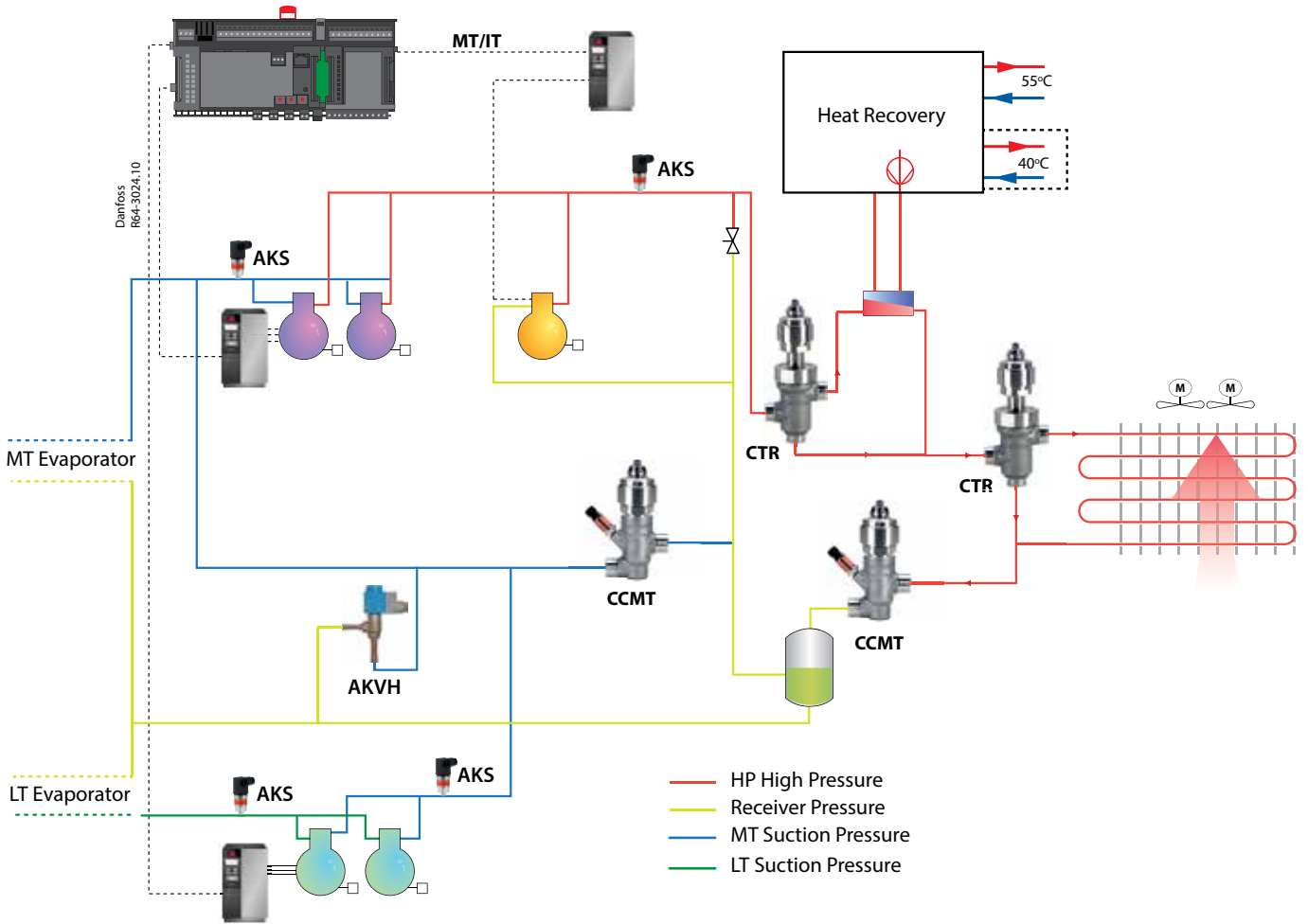

In CO₂ systems, the higher pressure and temperature make it possible to recover heat for tap water and heating. The excess heat is removed using a gas cooler. Regulation is carried out during transcritical and subcritical states and the controller will control the gas pressure/condensing pressure so that the system achieves the optimum COP when the recovered heat is taken into account. The regulation of the heat recovery circuits is done with regard to the cooling system. In the event of conflict, the safety situation is that the cooling system has higher priority than the recovery circuits.

The two heat recovery circuits can be considered as independent circuits - also with regard to the cooling system. First, the circuit for hot tap water will take the energy it needs to use. The remaining energy is then available for use by the next circuit. This also takes what is available. If there is then any excess energy, this is removed via the gas cooler. There must be a cooling requirement in order to supply for heat recovery.

Application example

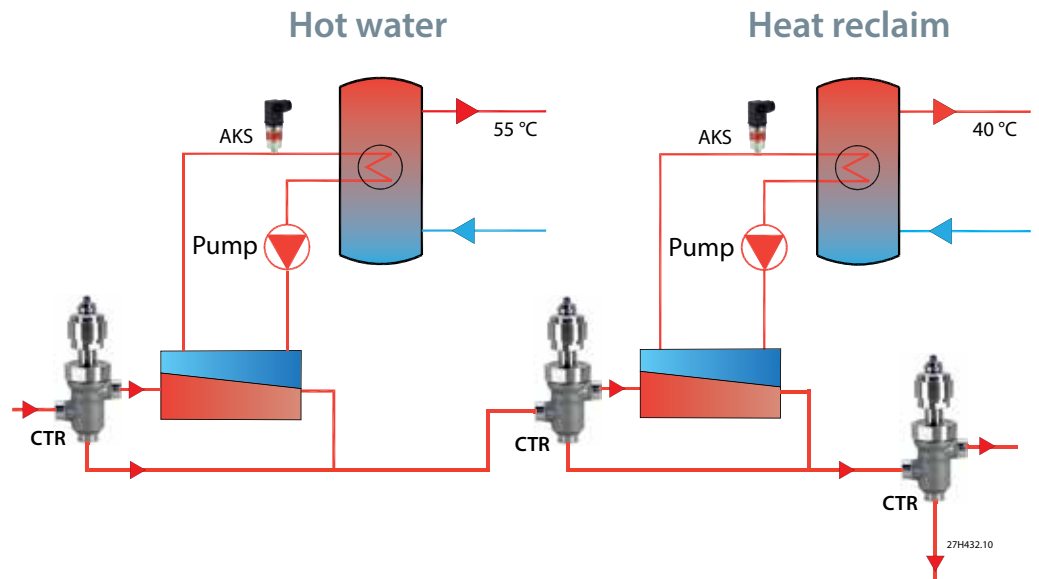

CTR Valve provides Modulating operation to ensure smooth transition avoiding too many Compressor on/off when going from Heat reclaim mode to full through Gas Cooler.

In the above example, the 3-way valve switches to enable flow of hot gas to enter heat reclaim heat exchanger. Here heat is transitioned to the water loop hence the Hot Gas is cooled. On the diagram, first heat is used for Hot Tap water and then with a second 3-way valve heat used for

the heating loop for the building, finally a third 3-way valve is mounted to enable by-pass of the gas cooler if that is needed. E.g. in a very cold season, where the pressure would drop too much after recovering all the heat in the plate heat exchangers.

 **Warning**

If the pressure drop in the heat exchanger and connecting pipes are less than 3 bar, the valve can be installed in any way the users likes based on the application. However, if there for some reason is a larger pressure drop than the MOPD of the valve then the right connection of the valve, as shown on the following diagram, is important for safety reasons.

If the connections is done as shown in the diagram, then the valve will always be able to go out of heat recovery mode and will always be able to let the gas cooler into operation no matter what pressure drop is in the heat exchanger and piping. Therefore, advises that the valve is always installed according to the diagram.

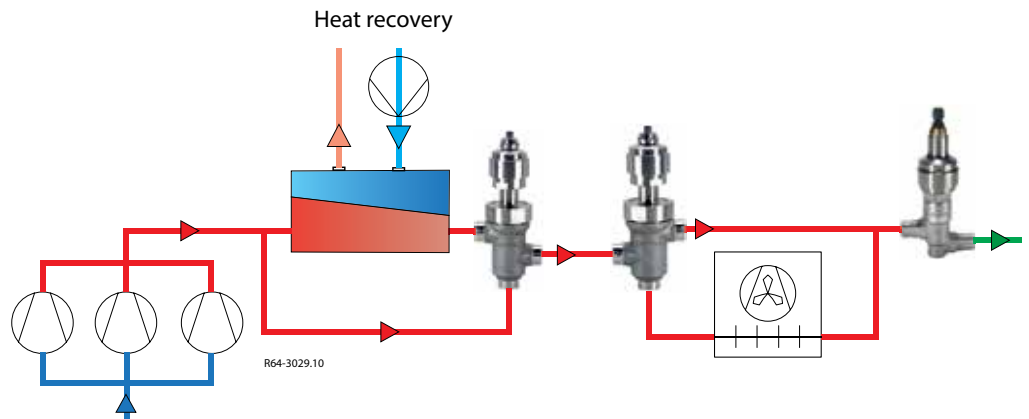

Flow characteristics

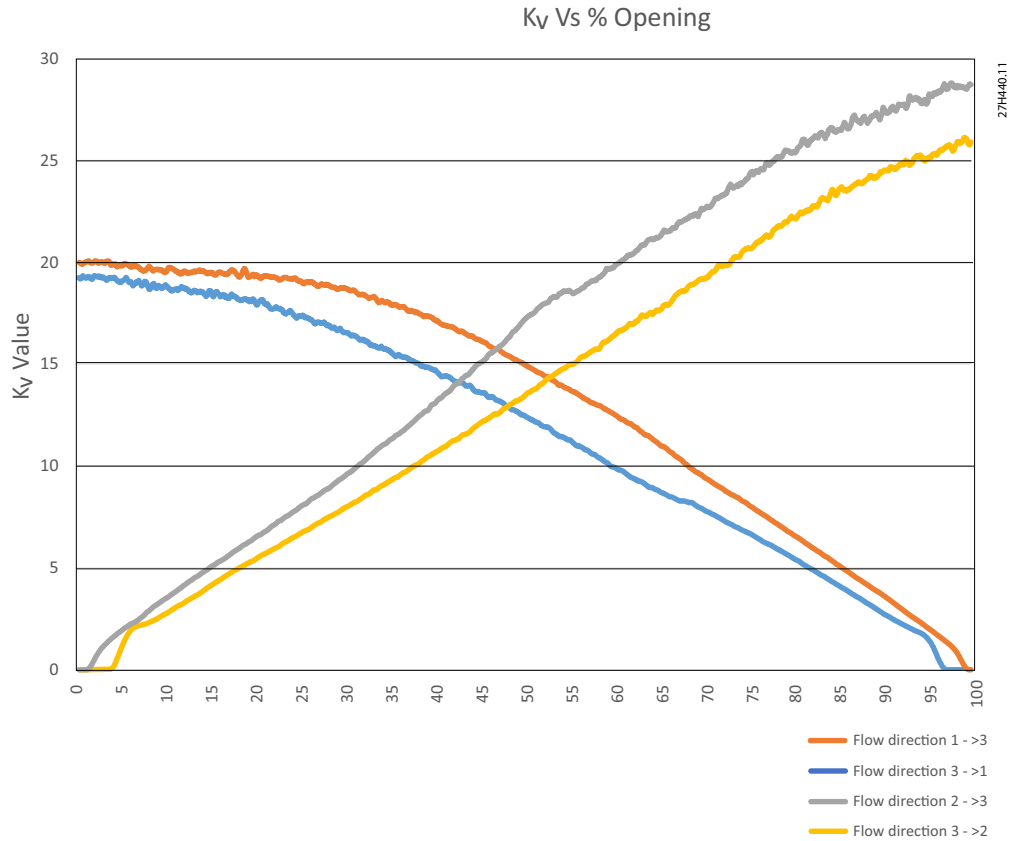

Driving CTR valve

CTR valve uses a bipolar, 2-phase, permanent magnet stepper motor. CTR valve can be driven using various electronic control techniques i.e.: Full step excitation mode, half step excitation mode, micro stepping mode (recommended). On selecting controller from other manufacturer than Danfoss, it is necessary to set the correct valve data into the controller setting. The wrong settings may impair the performance of the valve.

- Total no. of step
- Step rate
- Phase current
- Overdriving against closing position



Note:

If the controller driving the CTR valve is from another manufacturer than Danfoss or a custom design, the following points must be considered in order to overcome potential step loss. To ensure total closing of the valve, and to compensate the lost steps after a defined number of changes in opening degree, the controller should have a function to overdrive the valve in the closing direction. It is recommended to overdrive the valve at appropriate intervals.

Cable length

Depending on the type of controller or driver, there will be limitations in cable length between the controller / driver and the valve. Both the actual cable length, the level of EMC emission on the location and the driver circuit have an impact on the actual distortion of the current to the motor.



Warning

At power failure the CTR valve will remain in the actual opening position it has at the moment of power failure, unless a device in the form of a battery backup to the controller is installed.

Stepper motor switch sequence

The following table shows the full step excitation switching sequence

	STEP	Coil I (B)		Coil II (A)	
		Red	Green	White	Black
CLOSING ↑	1	+	-	+	-
	2	+	-	-	+
	3	-	+	-	+
	4	-	+	+	-
	1	+	-	+	-
					↓ OPENING

Color code is only valid for Danfoss M12 cable

Danfoss cable connections

Pin	Wire color
A1	White
A2	Black
B1	Red
B2	Green

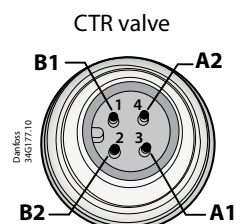

Dimensions and weight

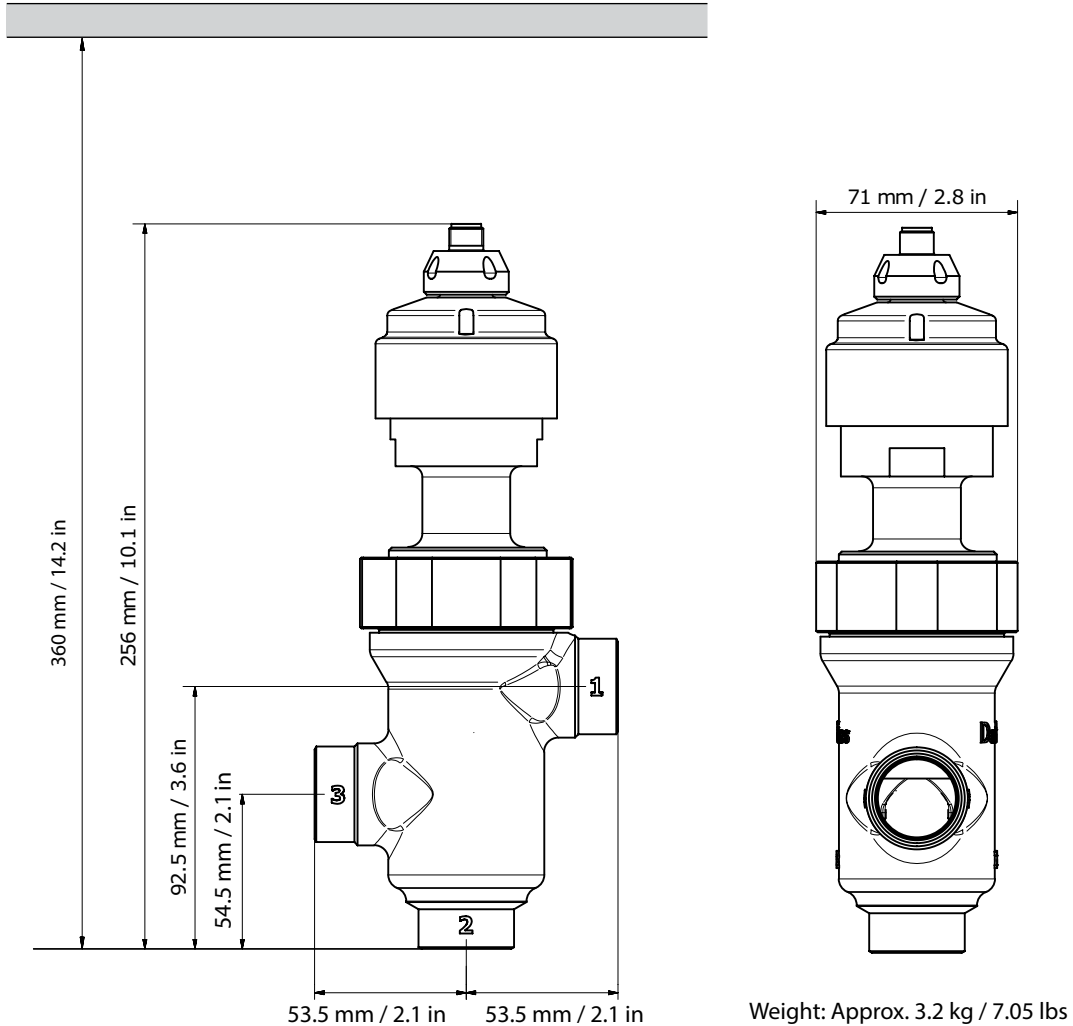

Архангельск (8182)63-90-72
 Астана (7172)727-132
 Астрахань (8512)99-46-04
 Барнаул (3852)73-04-60
 Белгород (4722)40-23-64
 Брянск (4832)59-03-52
 Владивосток (423)249-28-31
 Волгоград (844)278-03-48
 Вологда (8172)26-41-59
 Воронеж (473)204-51-73
 Екатеринбург (343)384-55-89

Иваново (4932)77-34-06
 Ижевск (3412)26-03-58
 Казань (843)206-01-48
 Калининград (4012)72-03-81
 Калуга (4842)92-23-67
 Кемерово (3842)65-04-62
 Киров (8332)68-02-04
 Краснодар (861)203-40-90
 Красноярск (391)204-63-61
 Курск (4712)77-13-04
 Липецк (4742)52-20-81

Магнитогорск (3519)55-03-13
 Москва (495)268-04-70
 Мурманск (8152)59-64-93
 Набережные Челны (8552)20-53-41
 Нижний Новгород (831)429-08-12
 Новокузнецк (3843)20-46-81
 Новосибирск (383)227-86-73
 Омск (3812)21-46-40
 Орел (4862)44-53-42
 Оренбург (3532)37-68-04
 Пенза (8412)22-31-16

Пермь (342)205-81-47
 Ростов-на-Дону (863)308-18-15
 Рязань (4912)46-61-64
 Самара (846)206-03-16
 Санкт-Петербург (812)309-46-40
 Саратов (845)249-38-78
 Севастополь (8692)22-31-93
 Симферополь (3652)67-13-56
 Смоленск (4812)29-41-54
 Сочи (862)225-72-31
 Ставрополь (8652)20-65-13

Сургут (3462)77-98-35
 Тверь (4822)63-31-35
 Томск (3822)98-41-53
 Тула (4872)74-02-29
 Тюмень (3452)66-21-18
 Ульяновск (8422)24-23-59
 Уфа (347)229-48-12
 Хабаровск (4212)92-98-04
 Челябинск (351)202-03-61
 Череповец (8202)49-02-64
 Ярославль (4852)69-52-93

Киргизия (996)312-96-26-47 Казахстан (772)734-952-31 Таджикистан (992)427-82-92-69

<http://dnfklapan.nt-rt.ru/> || dsf@nt-rt.ru