

Data Sheet

Solenoid valves Type **EV227B**

For neutral brines in cooling applications.

EV227B is a servo-operated 2/2-way solenoid valve programme, designed with diaphragm in softer material and with stronger armature spring for optimum closing at low pressure differences.

Features:

- For neutral brines
- Clip on coil
- Ambient temperature: Up to 50 °C
- Coil enclosure: Up to IP67
- Stainless steel screws for optimum corrosion resistance

Архангельск (8182)63-90-72
Астана (7172)727-132
Астрахань (8512)99-46-04
Барнаул (3852)73-04-60
Белгород (4722)40-23-64
Брянск (4832)59-03-52
Владивосток (423)249-28-31
Волгоград (844)278-03-48
Вологда (8172)26-41-59
Воронеж (473)204-51-73
Екатеринбург (343)384-55-89

Иваново (4932)77-34-06
Ижевск (3412)26-03-58
Казань (843)206-01-48
Калининград (4012)72-03-81
Калуга (4842)92-23-67
Кемерово (3842)65-04-62
Киров (8332)68-02-04
Краснодар (861)203-40-90
Красноярск (391)204-63-61
Курск (4712)77-13-04
Липецк (4742)52-20-81

Магнитогорск (3519)55-03-13
Москва (495)268-04-70
Мурманск (8152)59-64-93
Набережные Челны (8552)20-53-41
Нижний Новгород (831)429-08-12
Новокузнецк (3843)20-46-81
Новосибирск (383)227-86-73
Омск (3812)21-46-40
Орел (4862)44-53-42
Оренбург (3532)37-68-04
Пенза (8412)22-31-16

Пермь (342)205-81-47
Ростов-на-Дону (863)308-18-15
Рязань (4912)46-61-64
Самара (846)206-03-16
Санкт-Петербург (812)309-46-40
Саратов (845)249-38-78
Севастополь (8692)22-31-93
Симферополь (3652)67-13-56
Смоленск (4812)29-41-54
Сочи (862)225-72-31
Ставрополь (8652)20-65-13

Сургут (3462)77-98-35
Тверь (4822)63-31-35
Томск (3822)98-41-53
Тула (4872)74-02-29
Тюмень (3452)66-21-18
Ульяновск (8422)24-23-59
Уфа (347)229-48-12
Хабаровск (4212)92-98-04
Челябинск (351)202-03-61
Череповец (8202)49-02-64
Ярославль (4852)69-52-93

Киргизия (996)312-96-26-47 Казахстан (772)734-952-31 Таджикистан (992)427-82-92-69

<http://dnfklapan.nt-rt.ru/> || dsf@nt-rt.ru

1 Portfolio overview

Table 1: Portfolio overview

| Features | EV227B |
|--|--|
| |  |
| Body material | Brass |
| DN [mm] | 10-22 |
| Connection | G $\frac{3}{8}$ " - G1" |
| Sealing material | EPDM |
| Function | NC |
| Kv [m³/h] | 1.5 - 5.5 |
| Differential pressure range [bar] | 0.1 - 5 |
| Temperature range [°C] | -35 - 60 |

2 Application

It is recommended to use a filter in front of the valve. Recommended filter 50 mesh (297 microns).

Figure 1: Filter

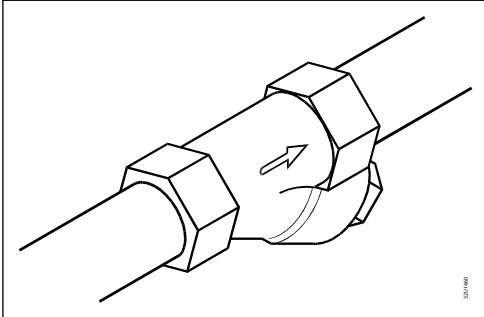

In water applications, exercise the valves at least once every 24 hours, meaning change the state of the valve. The valve exercise will minimize the risk of the valve sticking due to calcium carbonate, zinc or iron oxide build-up.

Figure 2: Exercise: Valve on/off

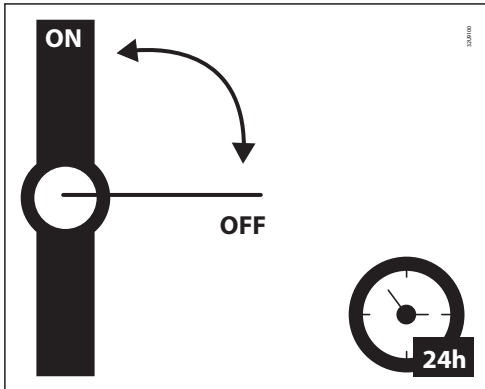

To minimize scaling, and corrosion attack it is recommended that the water passing the valve have the following values:

- Hardness 6 – 18 °dH to avoid scaling (chalk / lime stone build up)
- Conductivity 50 – 800 µS/cm to avoid brass dezincification and corrosion.
- Above 25 °C media temperature avoid stagnant water inside the valve to avoid dezincification and corrosion attack.

3 Product specification

3.1 Technical data

Table 2: Technical data

| | | |
|--|--|--------------------|
| Media | EPDM | For neutral brines |
| Media temperature [°C] | EPDM | -35 – 60 °C |
| Kv value [m³/h] | DN10 | 1.5 m³/h |
| | DN12 | 2.5 m³/h |
| | DN14 | 3.5 m³/h |
| | DN18 | 5.5 m³/h |
| | DN22 | 5.5 m³/h |
| | Min. Opening differential pressure [bar] | 0.1 bar |
| Max. Opening differential pressure [bar] | 5 bar | |
| Max. working pressure [bar] | 5 bar | |
| Max. test pressure [bar] | 16 bar | |
| Viscosity [cSt] | Max. 50 cSt | |

Table 3: Indicative capacity correction factors for different viscosities

| Viscosity, mm²/s | 10 | 20 | 30 | 40 | 50 |
|-------------------|------|------|------|------|------|
| Correction factor | 1.10 | 1.15 | 1.20 | 1.30 | 1.45 |

Multiply the capacity (m³/h) with the viscosity to find the EV227B valve that complies with the correction factor of the brine selected for the corrected capacity system. Then use the water capacity diagram.

Capacity diagram

Example, water: EV227B 12 at differential pressure of 1 bar: Approx. 2.5 m³/h

Figure 3: Capacity diagram

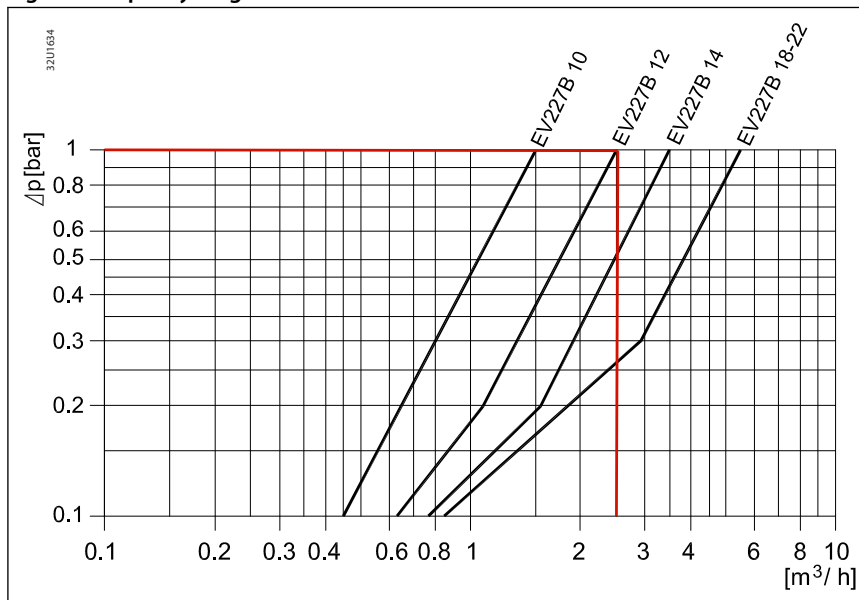

Time to open/close

Table 4: Time to open/close

| Main type | EV227B 10 | EV227B 12 | EV227B 14 | EV227B 18 | EV227B 22 |
|-----------------------------------|-----------|-----------|-----------|-----------|-----------|
| Time to open [ms] ⁽¹⁾ | 50 | 60 | 100 | 200 | 200 |
| Time to close [ms] ⁽¹⁾ | 300 | 300 | 400 | 500 | 500 |

⁽¹⁾ The times are indicative.

Materials

Table 5: Materials

| Components | Materials | Specifications |
|---------------|-----------------|----------------|
| Valve body | Brass | W.no. 2.0402 |
| Cover | Stainless steel | W.no. 1.4301 |
| Armature tube | Stainless steel | W.no. 1.4306 |
| Diaphragm | EPDM | - |
| Screws | Stainless steel | - |

3.2 Dimension and weight

Table 6: Dimension and weight

| Type | L [mm] | B [mm] | B ₁ /L ₁ [mm] Coil type | | | | H ₁ [mm] | H ₂ [mm] | Weight without coil [kg] |
|-----------|--------|--------|---|----------------|----------------|----------------|---------------------|---------------------|--------------------------|
| | | | BE | | BG | | | | |
| | | | B ₁ | L ₁ | B ₁ | L ₁ | | | |
| EV227B 10 | 51 | 48 | 46 | 72 | 66 | 82 | 13 | 84 | 0.29 |
| EV227B 12 | 58 | 50 | 46 | 72 | 66 | 82 | 13 | 84 | 0.35 |
| EV227B 14 | 80 | 52 | 46 | 72 | 66 | 82 | 15 | 87 | 0.5 |
| EV227B 18 | 90 | 56 | 46 | 72 | 66 | 82 | 18 | 90 | 0.65 |
| EV227B 22 | 90 | 58 | 46 | 72 | 66 | 82 | 18 | 98 | 1 |

Figure 4: Dimension

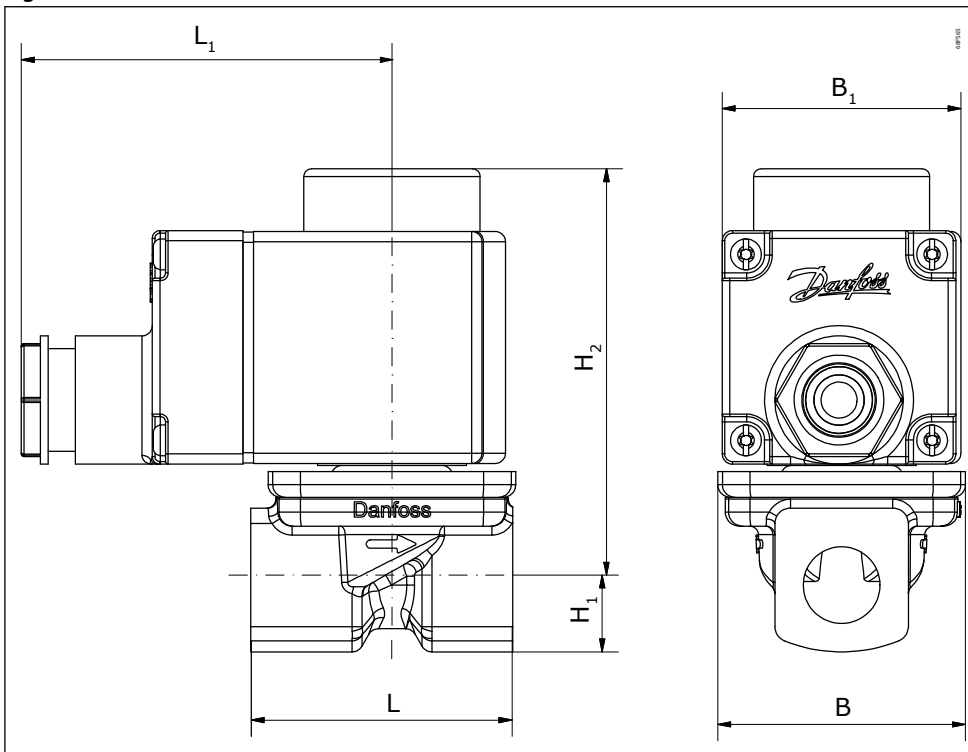

3.3 Mounting

Figure 5: Mounting angle

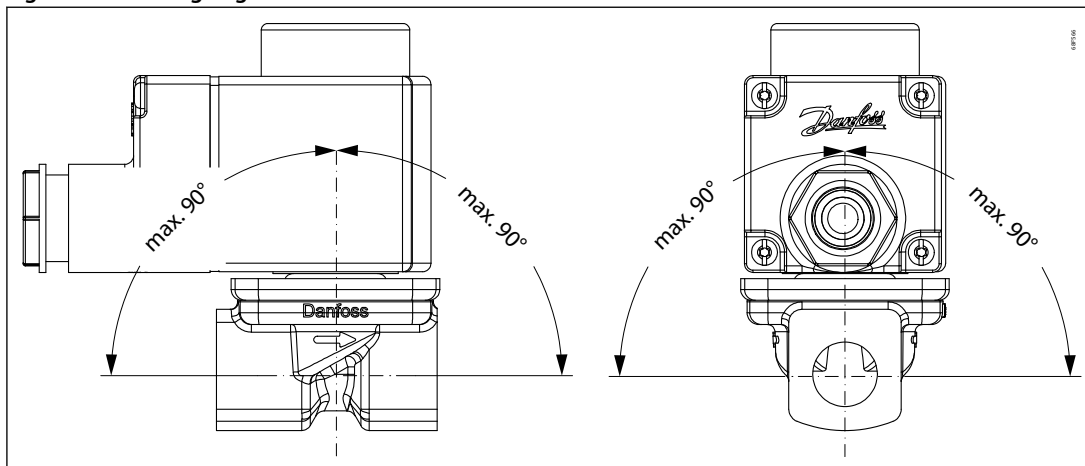

Архангельск (8182)63-90-72
 Астана (7172)727-132
 Астрахань (8512)99-46-04
 Барнаул (3852)73-04-60
 Белгород (4722)40-23-64
 Брянск (4832)59-03-52
 Владивосток (423)249-28-31
 Волгоград (844)278-03-48
 Вологда (8172)26-41-59
 Воронеж (473)204-51-73
 Екатеринбург (343)384-55-89

Иваново (4932)77-34-06
 Ижевск (3412)26-03-58
 Казань (843)206-01-48
 Калининград (4012)72-03-81
 Калуга (4842)92-23-67
 Кемерово (3842)65-04-62
 Киров (8332)68-02-04
 Краснодар (861)203-40-90
 Красноярск (391)204-63-61
 Курск (4712)77-13-04
 Липецк (4742)52-20-81

Магнитогорск (3519)55-03-13
 Москва (495)268-04-70
 Мурманск (8152)59-64-93
 Набережные Челны (8552)20-53-41
 Нижний Новгород (831)429-08-12
 Новокузнецк (3843)20-46-81
 Новосибирск (383)227-86-73
 Омск (3812)21-46-40
 Орел (4862)44-53-42
 Оренбург (3532)37-68-04
 Пенза (8412)22-31-16

Пермь (342)205-81-47
 Ростов-на-Дону (863)308-18-15
 Рязань (4912)46-61-64
 Самара (846)206-03-16
 Санкт-Петербург (812)309-46-40
 Саратов (845)249-38-78
 Севастополь (8692)22-31-93
 Симферополь (3652)67-13-56
 Смоленск (4812)29-41-54
 Сочи (862)225-72-31
 Ставрополь (8652)20-65-13

Сургут (3462)77-98-35
 Тверь (4822)63-31-35
 Томск (3822)98-41-53
 Тула (4872)74-02-29
 Тюмень (3452)66-21-18
 Ульяновск (8422)24-23-59
 Уфа (347)229-48-12
 Хабаровск (4212)92-98-04
 Челябинск (351)202-03-61
 Череповец (8202)49-02-64
 Ярославль (4852)69-52-93

Киргизия (996)312-96-26-47 Казахстан (772)734-952-31 Таджикистан (992)427-82-92-69