

Table of Contents	Contents
1.	Introduction2
2.	Features2
3.	Variants.....2
4.	Technical data3
5.	Flow3
5.1	VRH 5 Max. flow 5 l/ min.3
5.2	VRH 30 Max. flow 30 l/min.4
5.3	VRH 60 Max. flow 60 l/min.4
5.4	VRH 120 Max. flow 120 l/min.....5
5.5	VRH 120 F Max. flow 120 l/min.....5
6.	Mounting.....6
7.	Operation.....6
8.	Dimensions7
9.	Spare parts8

1. Introduction

The relief valve is used for protecting the components of a system against overload as a result of a pressure peak. Further, the valve is designed for controlling/ limiting the system pressure by draining off the surplus water from the pressure side.

The valve is designed for tap water, i.e. without additives of any kind to the medium. (EU-drinking water directive 98/83/EC).

2. Features

- Excellent functional characteristics.
- Surface easy to clean.
- Corrosion-proof parts (stainless steel, AISI 304, W. No. 1.4301).

3. Variants

The valves are available in four sizes:

- 5 l/min.
- 30 l/min.
- 60 l/min.
- 120 l/min.

Standard versions made of rustproof steel AISI 304/W. No. 1.4301. Upon request also available in versions made of stainless steel AISI 316L/W No. 1.4401

The relief valves are available with different pressure ranges.

Архангельск (8182)63-90-72
 Астана (7172)727-132
 Астрахань (8512)99-46-04
 Барнаул (3852)73-04-60
 Белгород (4722)40-23-64
 Брянск (4832)59-03-52
 Владивосток (423)249-28-31
 Волгоград (844)278-03-48
 Вологда (8172)26-41-59
 Воронеж (473)204-51-73
 Екатеринбург (343)384-55-89

Иваново (4932)77-34-06
 Ижевск (3412)26-03-58
 Казань (843)206-01-48
 Калининград (4012)72-03-81
 Калуга (4842)92-23-67
 Кемерово (3842)65-04-62
 Киров (8332)68-02-04
 Краснодар (861)203-40-90
 Красноярск (391)204-63-61
 Курск (4712)77-13-04
 Липецк (4742)52-20-81

Магнитогорск (3519)55-03-13
 Москва (495)268-04-70
 Мурманск (8152)59-64-93
 Набережные Челны (8552)20-53-41
 Нижний Новгород (831)429-08-12
 Новокузнецк (3843)20-46-81
 Новосибирск (383)227-86-73
 Омск (3812)21-46-40
 Орел (4862)44-53-42
 Оренбург (3532)37-68-04
 Пенза (8412)22-31-16

Пермь (342)205-81-47
 Ростов-на-Дону (863)308-18-15
 Рязань (4912)46-61-64
 Самара (846)206-03-16
 Санкт-Петербург (812)309-46-40
 Саратов (845)249-38-78
 Севастополь (8692)22-31-93
 Симферополь (3652)67-13-56
 Смоленск (4812)29-41-54
 Сочи (862)225-72-31
 Ставрополь (8652)20-65-13

Сургут (3462)77-98-35
 Тверь (4822)63-31-35
 Томск (3822)98-41-53
 Тула (4872)74-02-29
 Тюмень (3452)66-21-18
 Ульяновск (8422)24-23-59
 Уфа (347)229-48-12
 Хабаровск (4212)92-98-04
 Челябинск (351)202-03-61
 Череповец (8202)49-02-64
 Ярославль (4852)69-52-93

Киргизия (996)312-96-26-47 Казахстан (772)734-952-31 Таджикистан (992)427-82-92-69

4. Technical data

Type	Code no.	Pressure range barg (psig)	Setting screw (min. to max.) mm (inch)	Flow (max.) l/min. (gpm)	Media and ambient temperature °C (°F)	Internal leakage 20% below max.. setting pressure l/min. (gpm)	Weight kg (lbs)
VRH 5	180G0034	30-120 (435-1740)	5.3 (0.2)	5 (1.3)	50 (122)	up to 0.3 (up to 0.08)	0.62 (1.5)
VRH 5 CA ¹⁾	180G0033	30-120 (435-1740)	5.3 (0.2)	5 (1.3)	50 (122)	up to 0.3 (up to 0.08)	0.62 (1.5)
VRH 30	180G0030	25-140 (362-2030)	5.3 (0.2)	30 (7.9)	50 (122)	up to 0.3 (up to 0.08)	0.62 (1.5)
VRH 30	180G0029	10-40 (145-580)	5.3 (0.2)	30 (7.9)	50 (122)	up to 0.3 (up to 0.08)	0.62 (1.5)
VRH 30	180G0031	45-210 (652-3045)	5.3 (0.2)	30 (7.9)	50 (122)	up to 0.3 (up to 0.08)	0.62 (1.5)
VRH 30 CA ¹⁾	180G0032	25-140 (362-2030)	5.3 (0.2)	30 (7.9)	50 (122)	up to 0.3 (up to 0.08)	0.62 (1.5)
VRH 60	180G0002	25-80 (362-1160)	6.2 (0.24)	60 (15.8)	50 (122)	up to 1.0 (up to 0.3)	1.3 (2.4)
VRH 60	180G0003	80-140 (1160-2030)	6.2 (0.24)	60 (15.8)	50 (122)	up to 1.0 (up to 0.3)	1.3 (2.4)
VRH 120	180G0020	25-80 (362-1160)	7.3 (0.28)	120 (31.7)	50 (122)	up to 1.0 (up to 0.3)	2.8 (6.2)
VRH 120	180G0021	80-140 (1160-2030)	7.3 (0.28)	120 (31.7)	50 (122)	up to 1.0 (up to 0.3)	2.8 (6.2)
VRH 120 F ²⁾	180G0035	80-140 (1160-2030)	7.3 (0.28)	120 (31.7)	50 (122)	up to 1.0 (up to 0.3)	2.8 (6.2)

¹⁾ Cartridge version

²⁾ Fire fighting version - recommended inspection after 500 hours of operation

5. Flow

5.1 VRH 5 Max. flow: 5 l/min.

Pressure setting range: 30-140 barg (435-1740 psig)

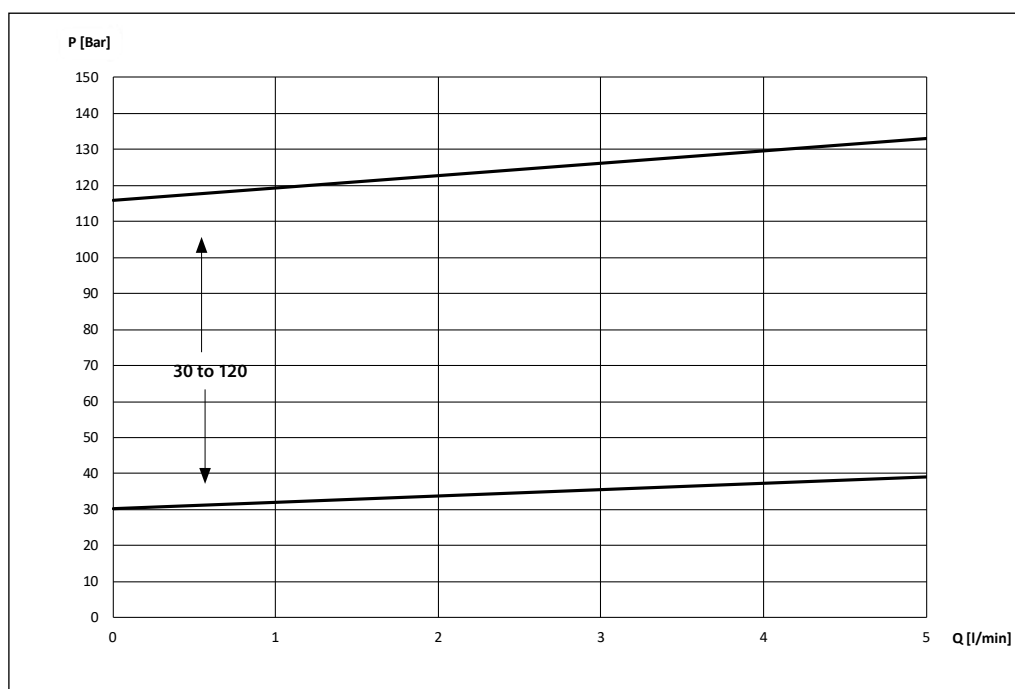

5.2 VRH 30 Max. flow: 30 l/min.

Pressure setting range: 10-40 barg, 25-140 barg, 45-210 barg
 (145-180 psig, 362-2030 psig, 652-3045 psig)

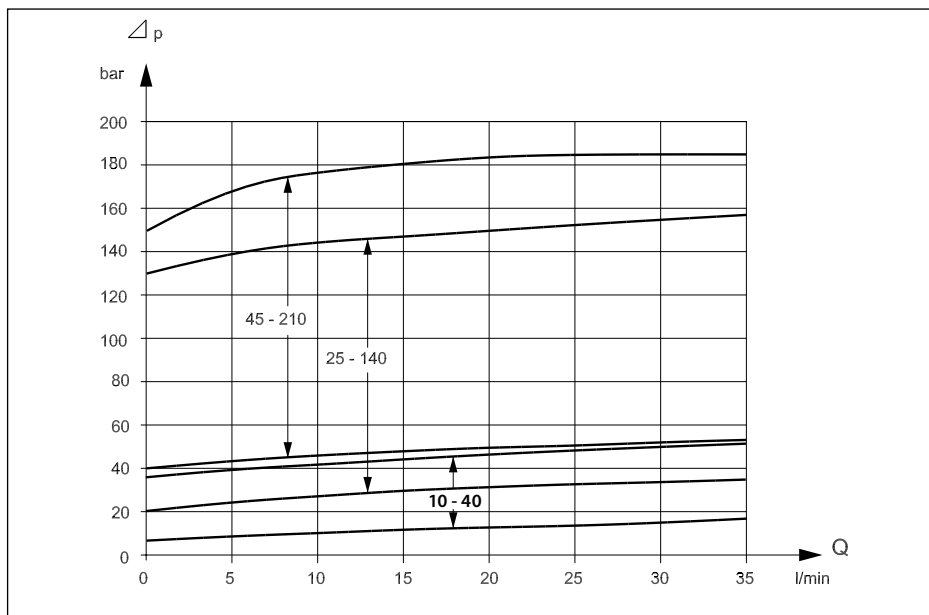

5.3 VRH 60 Max. flow: 60 l/min.

Pressure setting range: 25-80 barg, 80-140 barg
 (362-1160 psig, 1160-2030 psig)

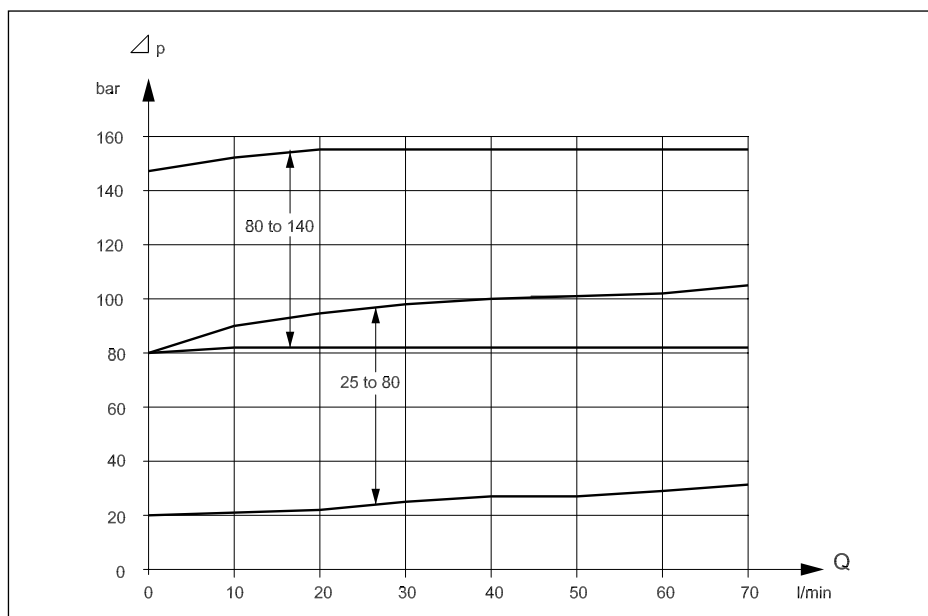

5.4 VRH 120 Max. flow: 120 l/min.
Pressure setting range: 25-80 barg, 80-140 barg
(362-1160 psig, 1160-2030 psig)

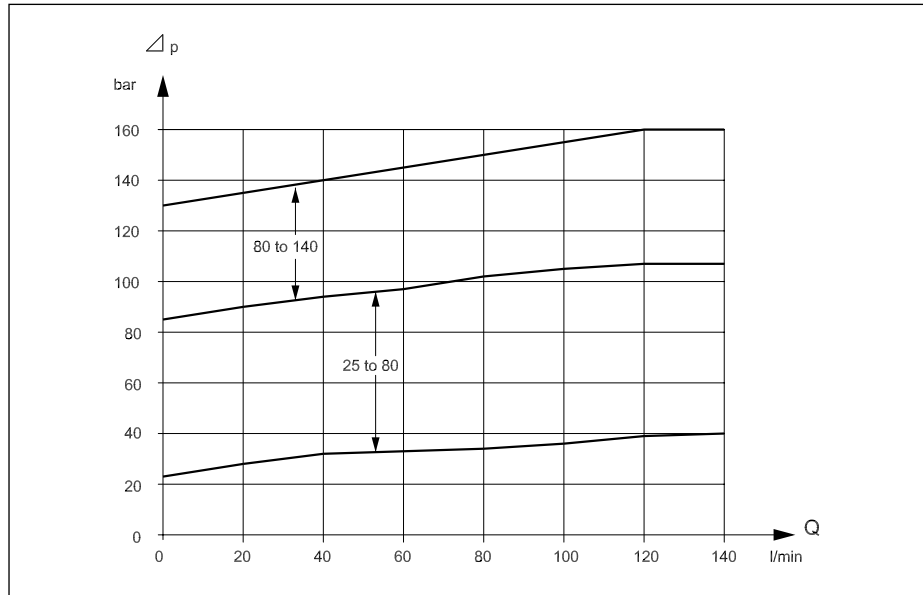

5.5 VRH 120F Max. flow: 120 l/min.
Pressure setting range: 80-140 barg
(1160-2030 psig)

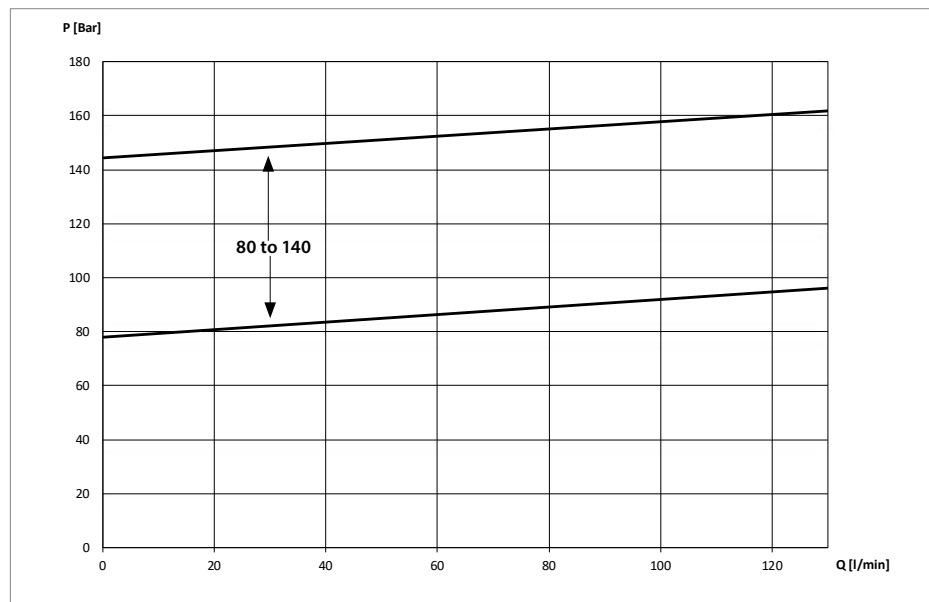

6. Mounting

The valve is mounted in-line and fixed by means of the system's piping or fastened (only VRH 120) by means of the two 8.4 mm holes in the valve.

It is important that valve is bleed to avoid noise and therefore must the valve be mounted in the correct position - please see drawing

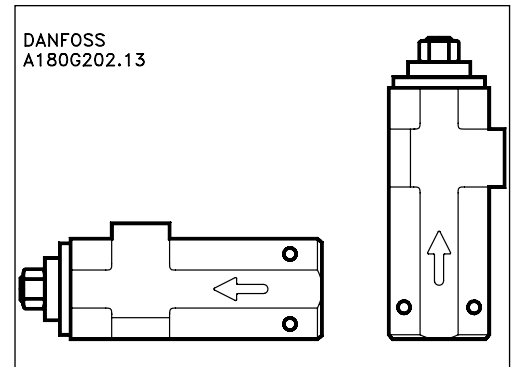

7. Operation

Starting up

To ensure stable working conditions for the valve it is very important to bleed the valve during starting up.

Noise level

Since the valve typically is mounted in-line or on a frame, the noise level can only be determined for the complete system, It is therefore very important that the valve is mounted correctly on a frame to minimize vibrations and noise.

The noise level is influenced by:

- Mounting position of the valve is important to ensure a good bleeding of valve.
- Sufficient bleeding of the valve.
- High pressure generates more noise than low pressure.
- Rigid mounting of the valve generates more noise than flexible mounting.
- Pipe mounting direct to the valve increases the noise level compared to a flexible hose connection.

Filtration

We strongly recommend that you always use precision depth filter cartridges in the system, rated 10 µm abs. $\beta_{10} \geq 5,000$. or better.

Corrosion and frost protection

If the valve is exposed to temperature below freezing, it must be protected against freezing. recommends DOWCAL N or Zitrec FC antifreezes both being biologically degradable Mono Propylene Glycol (MPG).

8. Dimensions

8.1 VRH 5, VRH 30, VRH 60 and VRH 120

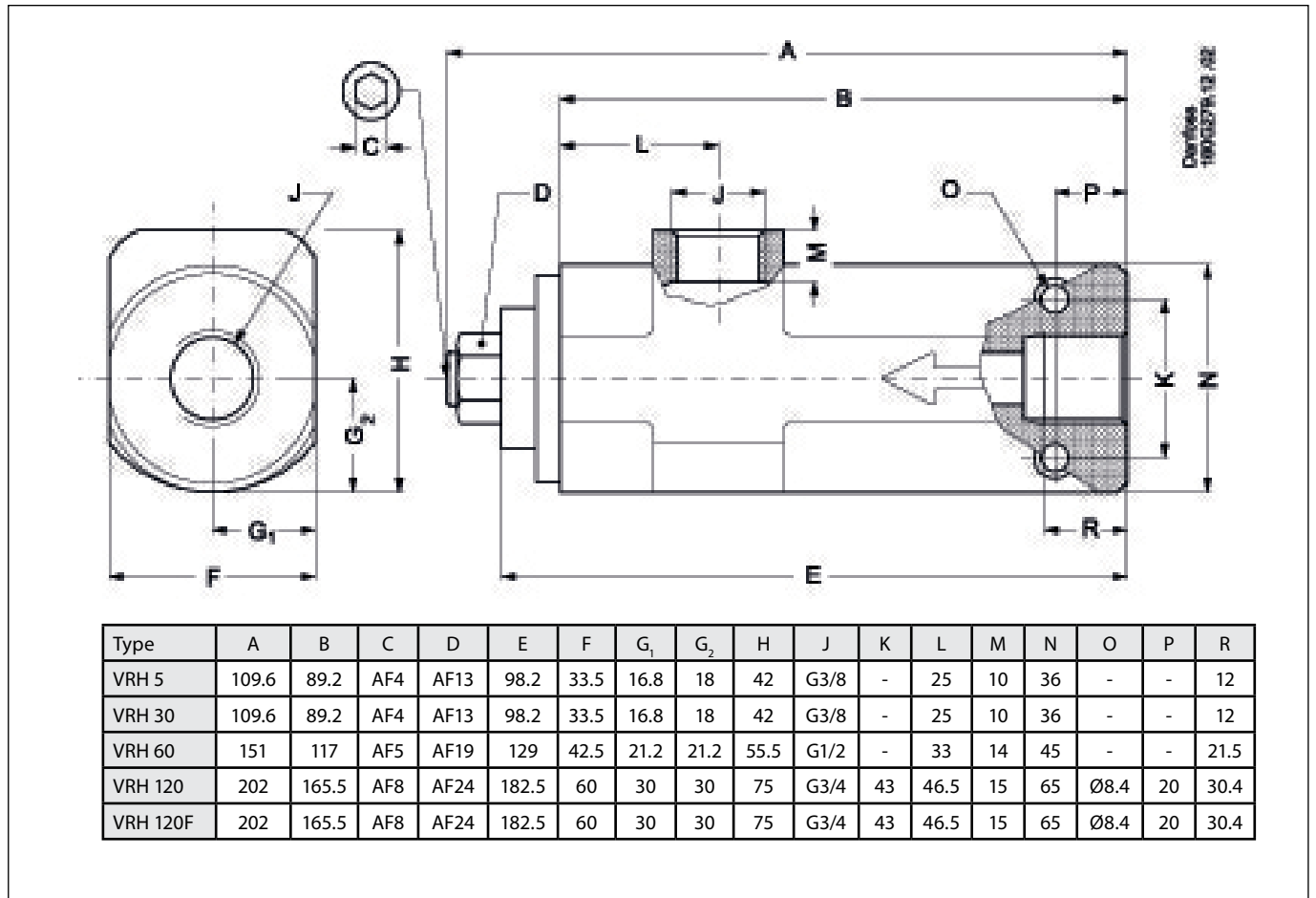

8.2 VRH 5 CA and VRH 30 CA

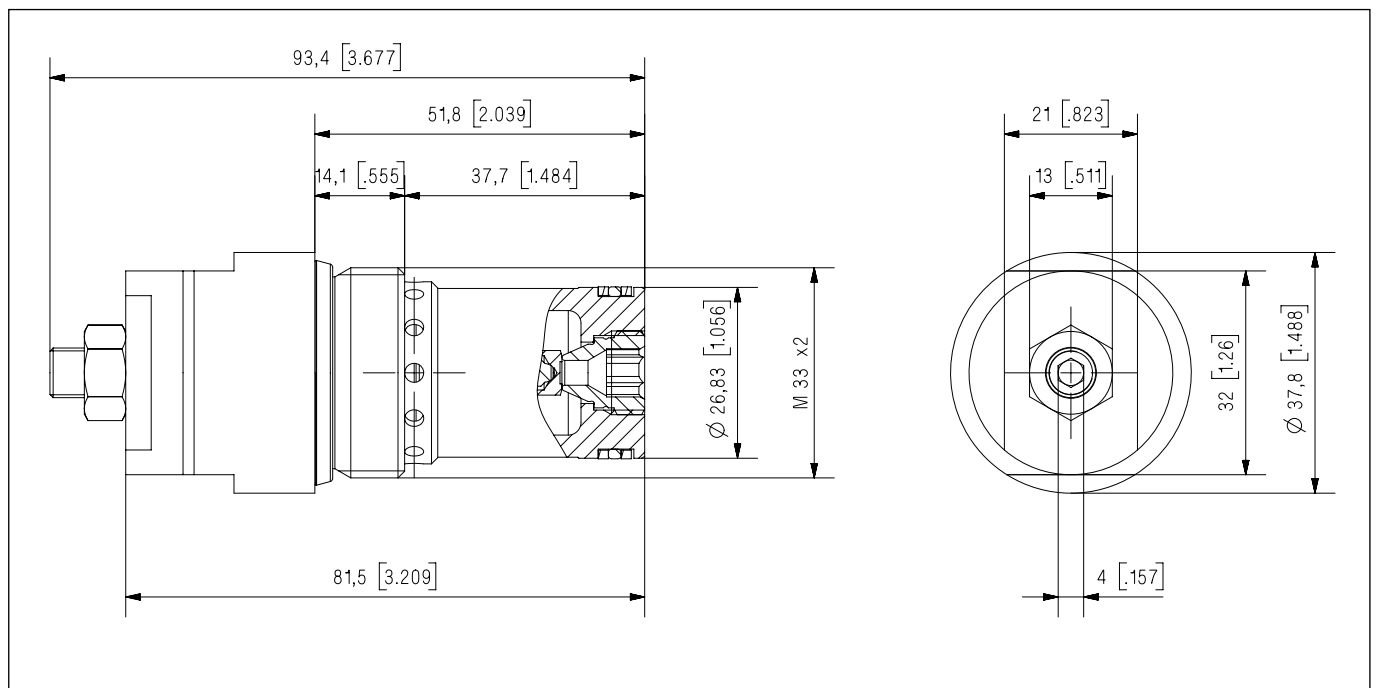

9. Spare parts

Valve size	Description	Code no.
VRH 5	Valve seat and cone kit 25-100 barg (362-1450 psig)	180G4018
VRH 5	Seal and spring kit	180G4019
VRH 30	Valve seat and cone kit [pressure range 10-40, 25-140 barg (145-580, 362-2030 psig)]	180G4000
VRH 5/30	Guide and guide pin kit	180G4001
VRH 30	Seal and spring kit [pressure range 10-40 barg (145-580 psig)]	180G4002
VRH 5/30	Tool kit	180G4003
VRH 30	Seal and spring kit [pressure range 25-140, 45-210 barg (362-2030, 652-3045 psig)]	180G4004
VRH 30	Valve seat and cone kit [pressure range 45-210 barg (652-3045 psig)]	180G4005
VRH 60	Valve seat and cone kit [pressure range 10-140 barg (145-2030 psig)]	180G4006
VRH 60	Guide and guide pin kit	180G4007
VRH 60	Seal and spring kit [pressure range 10-40 barg (145-580 psig)]	180G4008
VRH 60	Seal and spring kit [pressure range 25-60 barg (362-1160 psig)]	180G4009
VRH 60	Seal and spring kit [pressure range 80-140 barg (1160-2030 psig)]	180G4010
VRH 60	Tool kit	180G4011
VRH 120	Valve seat and cone kit [pressure range 25-140 barg (362-2030 psig)]	180G4012
VRH 120	Guide and guide pin kit	180G4013
VRH 120	Seal and spring kit [pressure range 25-80 barg (362-1160 psig)]	180G4014
VRH 120	Seal and spring kit [pressure range 80-140 barg (1160-2030 psig)]	180G4015
VRH 120	Tool kit	180G4016
VRH 120 F	Valve seat and cone kit [pressure range 80-140 barg (1160-2030 psig)]	180G4020

9.1 Recommendation for build in a VRH 5/30 CA

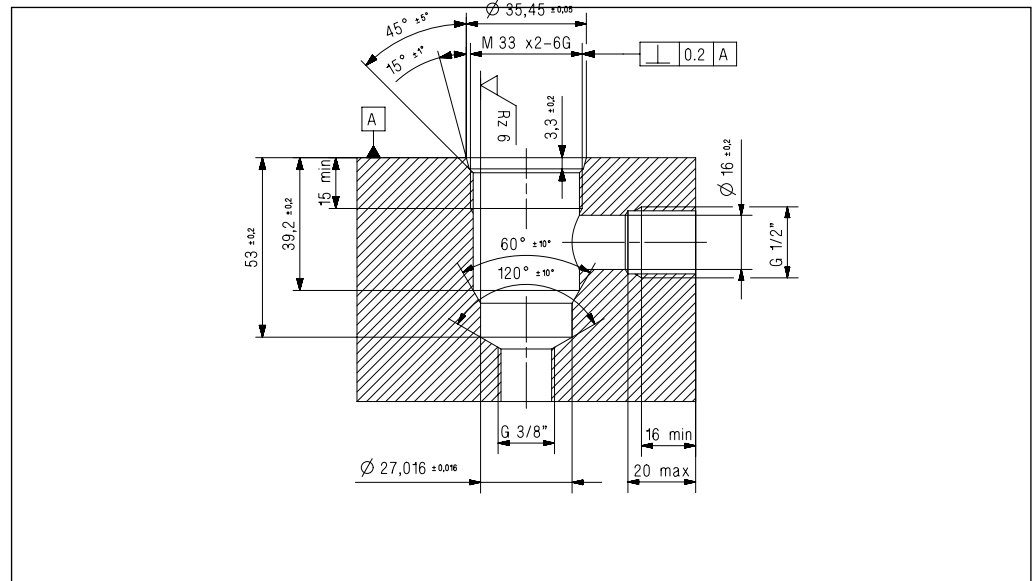

Архангельск (8182)63-90-72
 Астана (7172)727-132
 Астрахань (8512)99-46-04
 Барнаул (3852)73-04-60
 Белгород (4722)40-23-64
 Брянск (4832)59-03-52
 Владивосток (423)249-28-31
 Волгоград (844)278-03-48
 Вологда (8172)26-41-59
 Воронеж (473)204-51-73
 Екатеринбург (343)384-55-89

Иваново (4932)77-34-06
 Ижевск (3412)26-03-58
 Казань (843)206-01-48
 Калининград (4012)72-03-81
 Калуга (4842)92-23-67
 Кемерово (3842)65-04-62
 Киров (8332)68-02-04
 Краснодар (861)203-40-90
 Красноярск (391)204-63-61
 Курск (4712)77-13-04
 Липецк (4742)52-20-81

Магнитогорск (3519)55-03-13
 Москва (495)268-04-70
 Мурманск (8152)59-64-93
 Набережные Челны (8552)20-53-41
 Нижний Новгород (831)429-08-12
 Новокузнецк (3843)20-46-81
 Новосибирск (383)227-86-73
 Омск (3812)21-46-40
 Орел (4862)44-53-42
 Оренбург (3532)37-68-04
 Пенза (8412)22-31-16

Пермь (342)205-81-47
 Ростов-на-Дону (863)308-18-15
 Рязань (4912)46-61-64
 Самара (846)206-03-16
 Санкт-Петербург (812)309-46-40
 Саратов (845)249-38-78
 Севастополь (8692)22-31-93
 Симферополь (3652)67-13-56
 Смоленск (4812)29-41-54
 Сочи (862)225-72-31
 Ставрополь (8652)20-65-13

Сургут (3462)77-98-35
 Тверь (4822)63-31-35
 Томск (3822)98-41-53
 Тула (4872)74-02-29
 Тюмень (3452)66-21-18
 Ульяновск (8422)24-23-59
 Уфа (347)229-48-12
 Хабаровск (4212)92-98-04
 Челябинск (351)202-03-61
 Череповец (8202)49-02-64
 Ярославль (4852)69-52-93

Киргизия (996)312-96-26-47 Казахстан (772)734-952-31 Таджикистан (992)427-82-92-69